

**Electric Two-Stage, Two-Position
Room Thermostat
General Instructions**

Application

For on-off control applications requiring sequenced switching of two heating devices or two cooling devices.

Features

- Fixed switch differential.
- Adjustable staging differential.
- Dial stop pins to limit dial range.
- Lock cover screw kits available.
- Agency approval.
- Unit marked in °F or °C.
- Switch bases AT-607 and AT-608 available for custom applications.
- Mounts on single or 2-gang switch box, 4" x 4" (102 mm x 102 mm) surface box, or direct to wall (24 Vac only).

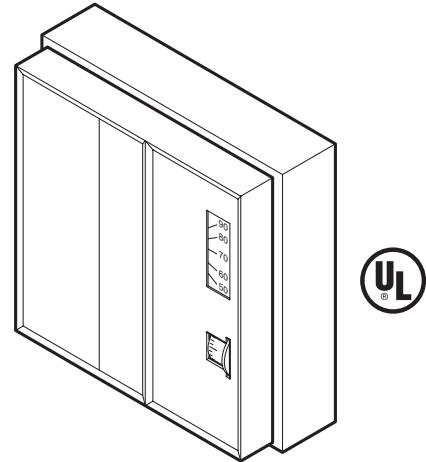

Applicable Literature

- TAC Environmental Controls Cross-Reference Guide, F-23638
- TAC Environmental Controls Reference Manual, F-21683
- TAC Environmental Controls Application Manual, F-21335
- TAC Pneumatic Products Catalog, F-27383

SPECIFICATIONS

Thermostat Inputs

Setpoint Dial Range: See Table-1.

Sensing Elements: Two Bimetals.

Differential:

Switching, 2°F (1.1 °C)

Staging, Adjustable 2 to 10°F (1.1 to 5.6°C), factory adjusted between 2 and 4°F,

Thermostat Outputs

Electrical:

Switch Action, See Table-1.

Amp Ratings, See Table-2.

Connections: Coded screw terminals.

Environment

Ambient Temperature Limits:

Shipping & Storage, -40 to 160°F (-40 to 71°C)

Operating, 40 to 140°F (4° to 60°C).

Humidity: 5 to 95% R.H., non-condensing.

Mounting: Flush on single or 2-gang switch box or 4" x 4" (102 mm x 102 mm) surface box or directly to wall (24 Vac only).

Location: NEMA Type 1.

Agency Listings:

UL 873: Underwriters Laboratories (File #E9429 Category Temperature Indicating and Regulating Equipment).

Table-1 Model Chart.

Model No.	Control Dial Range	Switch Action
TC-1151	55 to 85°F	2 SPDT
TC-1151-116	13 to 29°C	
TC-1151-770*	55 to 85°F	

* Contains TAC Robertshaw logo.

Table-2 Electrical Ratings.

Model No.	Full Load Amps		Locked Rotor Amps		Pilot Duty VA
	24/120 Vac	240 Vac	24/120 Vac	240 Vac	
TC-1151	3.0	1.5	18	9	28 @ 24 Vac 140 @ 120/240 Vac
TC-1151-116					
TC-1151-770*					

* Contains TAC Robertshaw logo.

Table-3 TC-1151 Series Includes.

Quantity	Description
1	Blank cover insert
1	Cover insert with setpoint dial cutout
2	5/64" Allen head screws for securing cover to thermostat base
1	5/64" Allen head wrench
2	Dial stop pins to limit setpoint range

Standard Cover

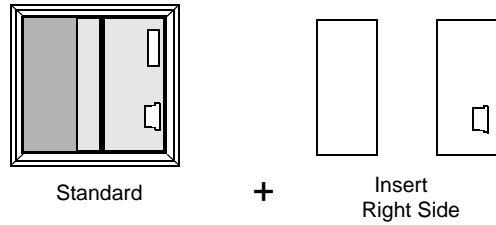

Options

Add "dash-number" (-XXX) suffix to base part number for desired option.



-500	Parallel Heat Anticipation	24V Standard Cover
-501	Parallel Heat Anticipation	120V Standard Cover
-502	Parallel Heat Anticipation	240V Standard Cover
-601	10°F Night Depression	120V Standard Cover
-602	10°F Night Depression	24V Standard Cover
-603	10°F Night Depression	240V Standard Cover

Normally, night depression is controlled by a centrally located time clock such as AE-174 or AE-178, or by selector switch sub-bases (AT-602 or AT-603).

ACCESSORIES

AT-101	Lock cover kit
AT-104	Dial stop pins (pins included with each unit)
AT-546	Auxiliary mounting plate
AT-607	Selector switch sub-base DP4T
AT-608	Selector switch sub-base one DP4T, one DPDT
AT-1155	Plastic guard
AT-1165	Plastic guard
TOOL-11	Calibration wrench
TOOL-13	Contact burnishing tool

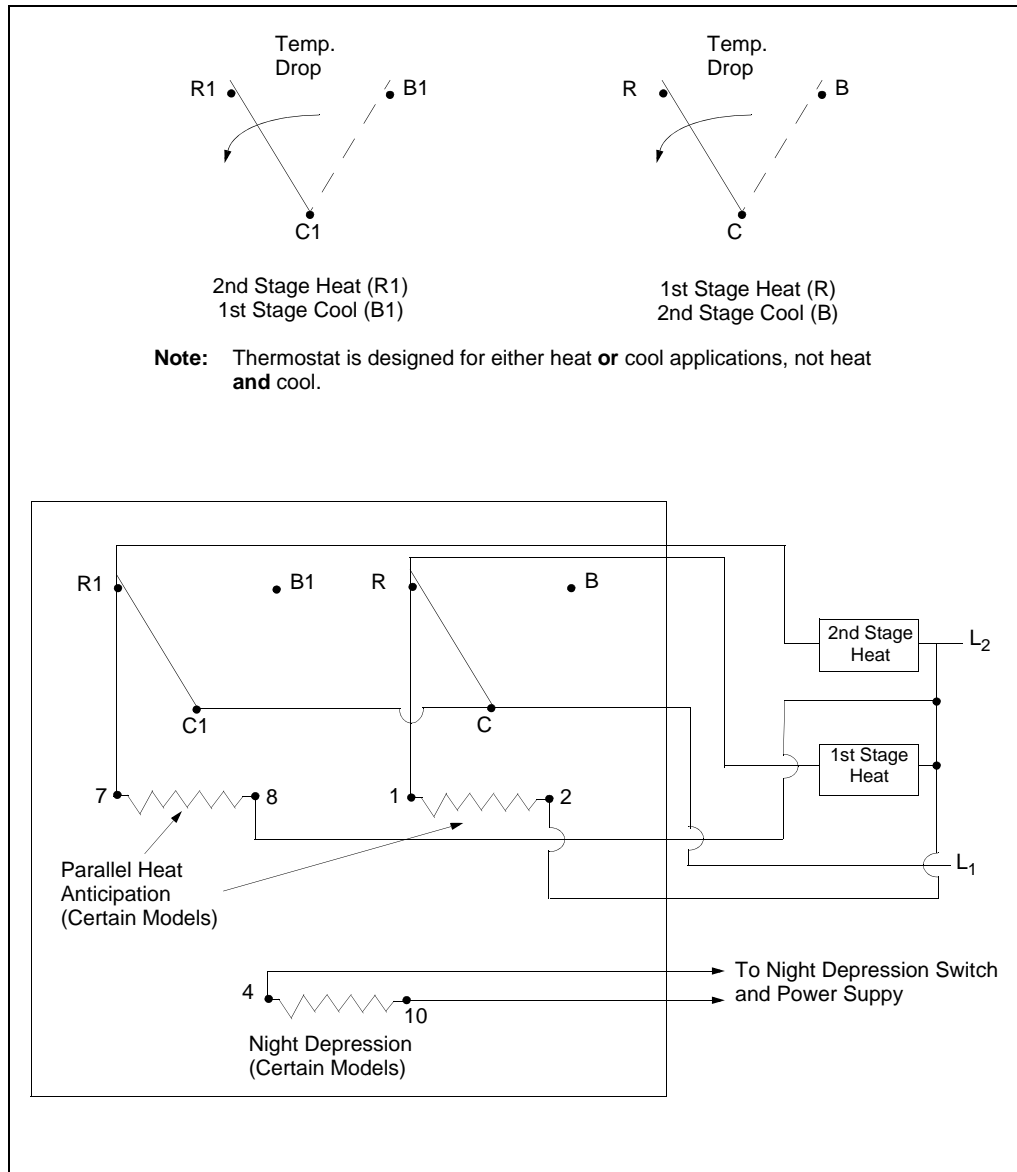

Figure-1 Terminal Designation and Typical Wiring Diagram for TC-1151 Series.

INSTALLATION

Inspection

Inspect the carton for damage. If damaged, notify the appropriate carrier immediately. Inspect the device for obvious damage. Return damaged products.

Requirements

- Job wiring diagrams
- Tools (not provided):
 - Volt-ohm meter
 - Appropriate screwdriver for mounting screws and terminal connections
- Appropriate accessories
- Mounting screws, four (4) provided for securing to a 4" x 4" (102 mm x 102 mm) conduit box
- Training: Installer must be a qualified, experienced technician



Warning:

- Disconnect power supply before installation to prevent electrical shock and equipment damage.
 - Make all connections in accordance with the wiring diagram and in accordance with national and local electrical codes. Class I wiring is required unless all circuits to contacts are powered from a Class II source. *Use copper conductors only.*
 - Do not locate the thermostat near sources of heat or cold such as lamps, motors, sunlight, or concealed ducts or pipes, or where there is a danger of electrocution (i.e., shower rooms).
-

Caution:

- Do not exceed ratings of the device(s).
 - The thermostat is not designed for service in any location where condensation may occur. Avoid locations where excessive moisture, corrosive fumes, or vibration is present. NEMA Type 1 covers are intended for indoor use primarily to provide a degree of protection against contact with the enclosed equipment.
 - Thermostats with guards that restrict air flow must have heating or cooling anticipation.
-

Mounting and Wiring

Thermostat requires upright mounting on a flat vertical surface. Locate thermostat where it is exposed to unrestricted circulation of air which represents the average temperature of the controlled space. (See Figure-2 and Figure-7 .)

1. Pull all wires.
2. Fasten mounting plate to box or wall.
3. Make electrical connection to thermostat screw type terminals. Green ground wire is located on mounting plate for use in all applications.
4. Hook thermostat on top of mounting plate and swing down into place.
5. Remove the two (2) thermostat cover screws and remove the thermostat cover.
6. Attach thermostat to mounting plate with mounting screw.
7. Attach thermostat cover and tighten the two (2) thermostat cover screws.

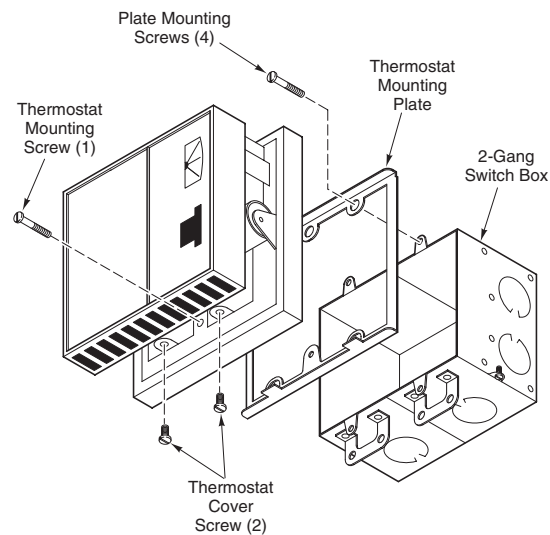

Figure-2 Thermostat Mounting.

CHECKOUT

After installing a thermostat, make an initial check of the switching action. Remove the thermostat cover by removing the two (2) thermostat cover screws. Verify the switch action by listening to and watching the switch contacts, using a volt-ohm meter between the proper sides of the switch, or by observing the controlled device.

1. Turn each setpoint dial to a temperature above ambient. First the "R" contact should make and then the "R1" contact should make.
2. Turn the setpoint dial setting down gradually. First the "B1" contact should make and then the "B" contact should make.

CALIBRATION

All thermostats are calibrated at the factory and normally do not require any such attention. However, if recalibration is necessary for any reason, proceed as follows:

1. Disconnect power to thermostat.
2. Set the adjusting dial to correspond to actual room temperature.
3. Remove thermostat cover, remove screw that secures right-hand side of insulator, fold back insulator, and remove contact cover. (See Figure-3 .)

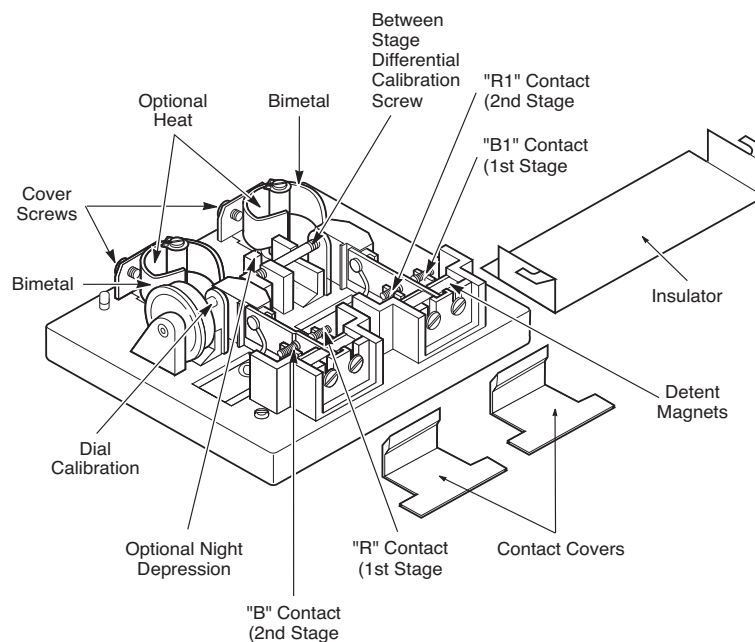

Figure-3 Part Identification.

Caution: Do not breathe on the thermostat or handle excessively as this affects the accuracy of the final calibration.

4. If the right contact blade is not made to the "R" contact, use a 3/16" open end wrench (TOOL-11) to turn calibration screw clockwise (looking at head of screw) until blade just makes "R" contact.

Note: Each complete revolution of the screw changes calibration approximately 6°F (3.3°C).

5. If the right contact blade is made to the "R" contact, turn the calibration screw slowly counterclockwise until the element makes the "B" contact.
6. Repeat steps 4 and 5 for the left contact blade. Thermostat is now properly calibrated.
7. Replace contact covers, insulator, and thermostat cover.
8. Restore power to thermostat.
9. Recheck calibration about 30 minutes later to be sure heat from handling did not result in erroneous setting.

ADJUSTMENTS

Concealed Control Dial

Knurled Dial Removal (See Figure-4)

1. Remove the thermostat cover.
2. Secure the control dial with your hand so that the dial does not rotate.
3. Place needle nose pliers on the knurled ring of the control dial at the points where the knurled ring is attached to the control dial.
4. Twist the pliers at each knurled ring attachment point until the entire knurled ring of the control dial is removed.

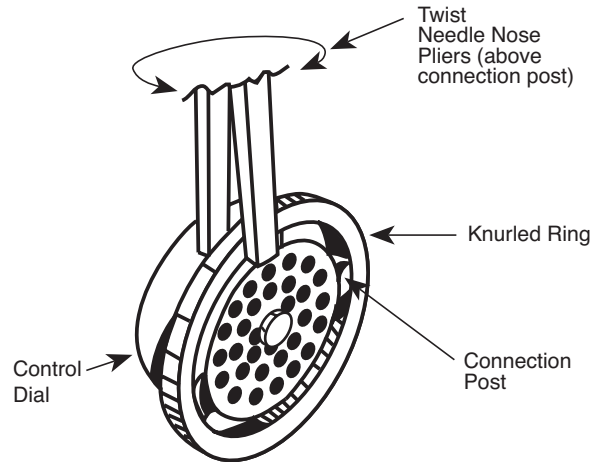

Figure-4 Knurled Dial Removal.

Cover Insert Installation

1. Select appropriate cover insert.

Note: If blank insert is used, the knurled ring must be removed from the setpoint dial. See Knurled Dial Removal section. Also, remove dial window by sliding and/or pressing window from front of cover.

2. Remove protective backing and protective skin on face of cover insert (see Figure-5).
3. Press insert uniformly on thermostat with logo in lower left-hand corner.

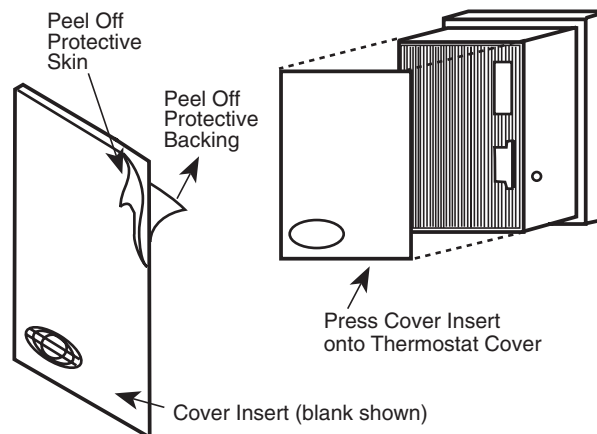

Figure-5 Cover Insert Installation.

Limit Control Dial Range

Dial Stop Pin Insertion (See Figure-6)

1. Remove thermostat cover.
2. Secure the control dial with your hand so that the dial does not rotate.
3. Place a dial stop pin in the jaws of a needle nose pliers.

4. Insert the dial stop pin in the appropriate hole on either (or both) side(s) of the control dial to restrict dial rotation.

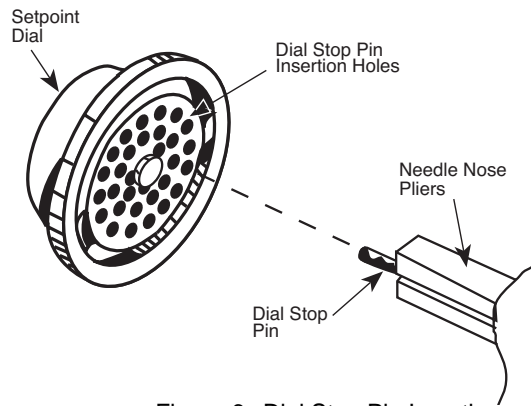

Figure-6 Dial Stop Pin Insertion.

MAINTENANCE

Open areas at bottom and around base of thermostat should be kept clean and free from obstructions to allow proper flow of air. If switch contacts need cleaning, this may be done with a contact burnishing tool (TOOL-13).

FIELD REPAIR

These thermostats are not field repairable. Replace entire device.

DIMENSIONAL DATA

All dimensions are in inches (millimeters in brackets). See Figure-7 .

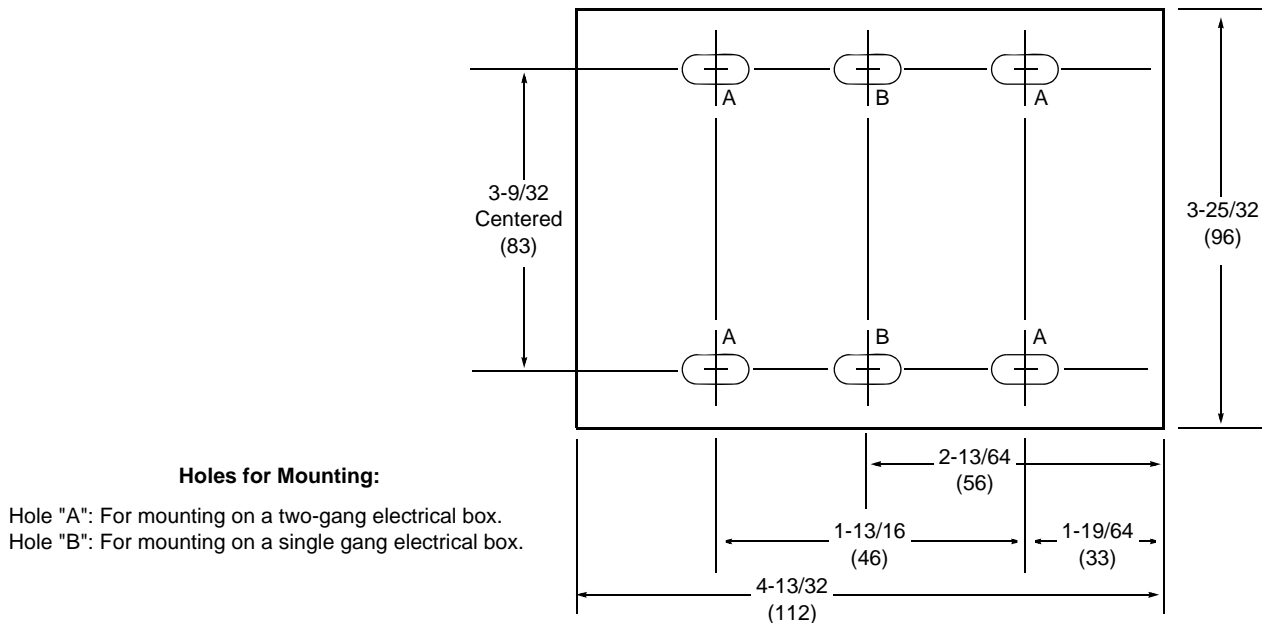

Figure-7 Mounting Ring Dimensions.